

Rely on FiSEC ingenuity.

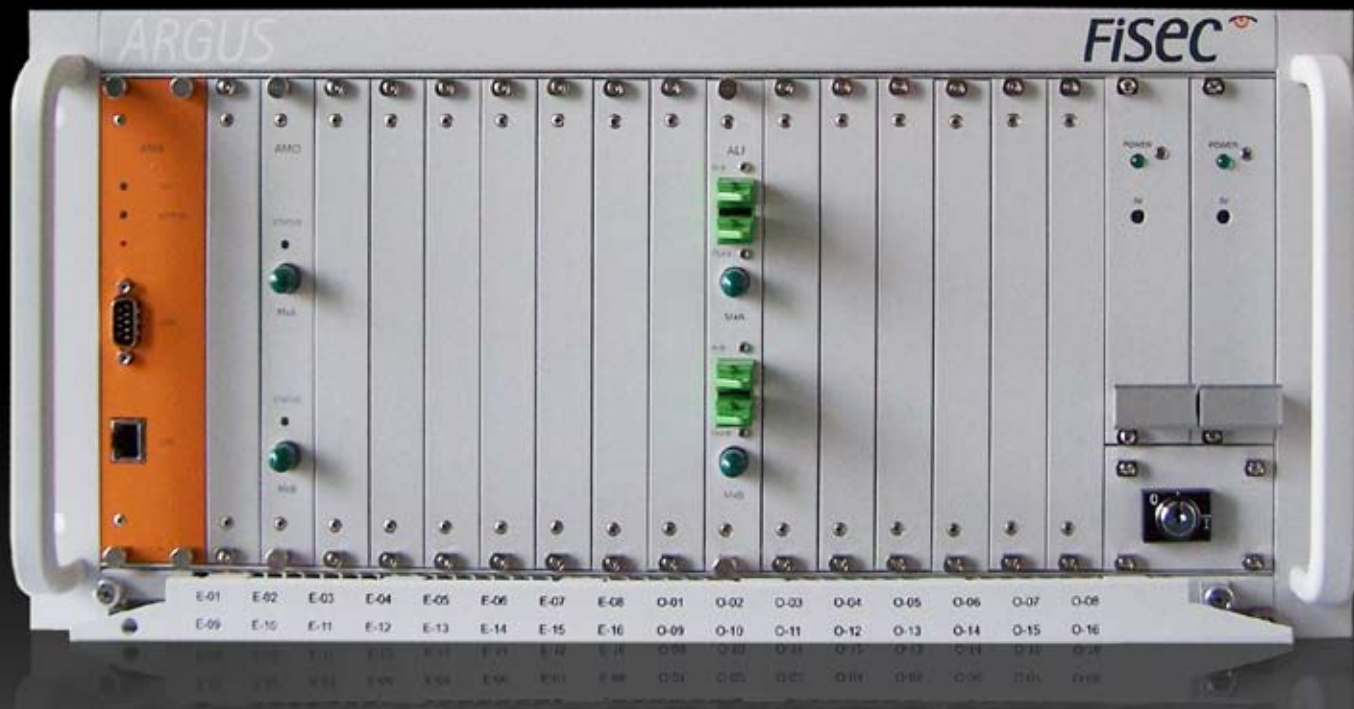

The ARGUS by FiSEC is an innovative instrument that offers 24/7 online monitoring of fiber optic networks in real-time. ARGUS is based on patented Correlation Optical Time Domain Reflectometer (C-OTDR) technology developed exclusively by FiSEC. Unlike other monitoring systems, ARGUS pinpoints the time and location of faults online in real-time. This capability is unique on today's market.

ARGUS advantages:

- Fault location and time online in real-time
- Increased system availability
- Reporting/documentation
- Weak point analysis
- Modular, space-saving design with 16 fibers
- In 19" rack, height: 4 U
- Web and SNMP integration
- Open system
- Easy to operate
- Inexpensive

ARGUS offers fiber optic network providers and users who rely on secure data transfers a significant increase in service availability. Fast response times and clear lines of responsi-

bility make it easier to quickly and efficiently correct faults. Unique in the industry, ARGUS makes it possible to actively monitor and manage complete fiber optic networks.

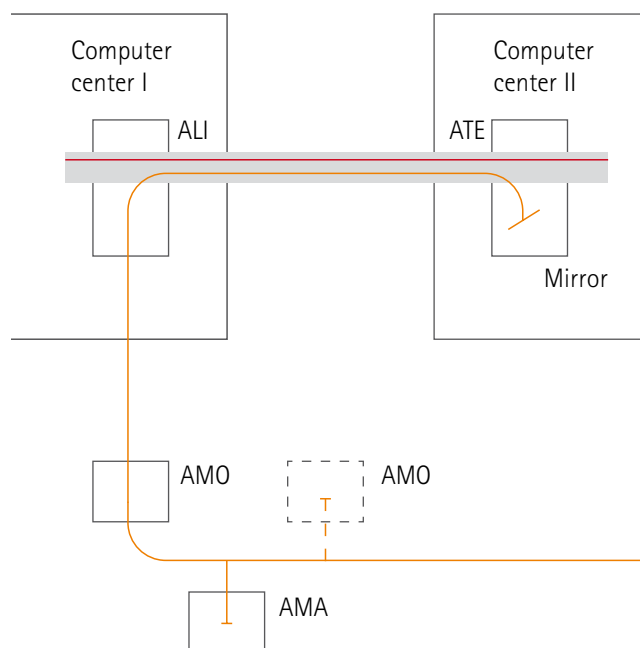

Specifications

Currently available hardware

- ARGUS Mainframe, chassis for ARGUS Modules
- ARGUS Manager Module (AMA), controller for analyzing/evaluating test results
- ARGUS Monitor Module (AMO), C-OTDR unit generates test results
- ARGUS Line Module (ALI), connects testing unit to the fiber link for monitoring
- ARGUS Termination Module (ATE), terminates the monitored fiber optic link/test signal

ARGUS Mainframe

Chassis for mounting ARGUS Modules

- 19" rack, height: 4U
- Power: 100 - 240 V / 50 - 60 Hz
- Dimensions: 480 W x 295 D x 220 H mm
- Operating temperature range: +5 to +45° C
- Humidity: 10 to 90%
- Slots: 8 active / 8 passive
- Redundant power supply
- Redundant cooling fans
- Monitoring up to 16 fiber optic links per Mainframe
- Key activated switch

ARGUS Line Module (ALI)

Connects testing unit to the fiber link for monitoring (optical module)

- Available versions: ALI duo, ALI one
- Wavelength: 1625 nm, 1310 nm, others available on request
- Input attenuation: $0,45 \pm 0,1$ dB (at 1550 nm), optimization on request
- Connectors:
 - ALI one: 1x E2000-In, 1x E2000-Out, 1x FC/APC
 - ALI duo: 2x E2000-In, 2x E2000-Out, 2x FC/APC

ARGUS Termination Module (ATE)

Terminates the monitored fiber optic link (optical module)

- Wavelength: 1625 nm, 1310 nm, others available on request
- Connectors: E2000-In, E2000-Out
- Input attenuation: $0,45 \pm 0,1$ dB (at 1550 nm), optimization on request

ARGUS Monitor Module (AMO) R.1.0.

C-OTDR unit – generates test results (electrical module)

- Available versions: AMO duo & AMO one
- Wavelength: 1625 nm (recommended), 1310 nm, others available on request
- Max. fiber length: 30,000 meters, longer distances available on request
- Fault location accurate to within $\pm 1,25$ m
- Fiber type: Standard Single Mode
- Fault recognition and positioning: < 3 s
- Sensitivity: < 0,3 dB
- Connectors:
 - AMO one: 1x FC/APC
 - AMO duo: 2x FC/APC
- Measuring technology: Correlation – Optical Time Domain Reflectometry (C-OTDR)
 - 256 measurement points
 - Horizontal resolution: min. 1,25 m
 - Vertical resolution: 16 Bit

ARGUS Manager Module (AMA) R.1.0.

Controller for analyzing/evaluating test results (electrical module)

- Hardware: Intel Celeron 733 MHz, 256 MB SDRAM, 40 GB HDD
- Operating system: Linux
- Software: ARGUS Management Server, Webserver (https), ARGUS web interface, database
- Connections: Ethernet, RS-232
- Indicators: power LED, status LED